

(17)

Table 4 Dimensions of Facings (Other Than Ring Joints, All Pressure Rating Classes)

1	2	3	4	5	6	7	8	9	10	11	12	13	14	15
Nominal Pipe Size	Outside Diameter				Outside Diameter				Height			Minimum Outside Diameter of Raised Portion [Notes (6), (7)]		
	Raised Face Large Male and Large Tongue, R	Small Male, S [Note (1)]	Small Tongue, T	Inside Diameter of Large and Small Tongue, U	Inside Diameter of Small Tongue [Note (1)]	Large Female and Large Groove, W	Small Female, X [Note (1)]	Small Groove, Y	Inside Diameter of Large and Small Groove, Z	Raised Face [Notes (2), (3)]	Large and Small Male and Tongue [Notes (2), (4)]	Depth of Groove or Female [Notes (2), (5)]	Small Female and Groove, K	Large Female and Groove, L
	1/2	34.9	18.3	35.1	25.4	...	36.5	19.9	36.5	23.8	...	...	...	44
3/4	42.9	23.8	42.9	33.3	...	44.4	25.4	44.4	31.8	...	...	...	52	54
1	50.8	30.2	47.8	38.1	...	52.4	31.8	49.2	36.5	...	...	...	57	62
1 1/4	63.5	38.1	57.2	47.6	...	65.1	39.7	58.7	46.0	...	...	...	67	75
1 1/2	73.0	44.4	63.5	54.0	...	74.6	46.0	65.1	52.4	...	...	...	73	84
2	92.1	57.2	82.6	73.0	...	93.7	58.8	84.1	71.4	...	...	...	92	103
2 1/2	104.8	68.3	95.2	85.7	...	106.4	69.8	96.8	84.1	...	...	...	105	116
3	127.0	84.1	117.5	108.0	...	128.6	85.7	119.1	106.4	...	...	...	127	138
3 1/2	139.7	96.8	130.2	120.6	...	141.3	98.4	131.8	119.1	...	...	...	140	151
4	157.2	109.5	144.5	131.8	...	158.8	111.1	146.0	130.2	...	...	...	157	168
5	185.7	136.5	173.0	160.3	...	187.3	138.1	174.6	158.8	...	...	...	186	197
6	215.9	161.9	203.2	190.5	...	217.5	163.5	204.8	188.9	...	...	...	216	227
8	269.9	212.7	254.0	238.1	...	271.5	214.3	255.6	236.5	...	...	...	270	281
10	323.8	266.7	304.8	285.8	...	325.4	268.3	306.4	284.2	...	...	...	324	335
12	381.0	317.5	362.0	342.9	...	382.6	319.1	363.5	341.3	...	...	...	381	392
14	412.8	349.2	393.7	374.6	...	414.3	350.8	395.3	373.1	...	...	...	413	424
16	469.9	400.0	447.5	425.4	...	471.5	401.6	449.3	423.9	...	...	...	470	481
18	533.4	450.8	511.2	489.0	...	535.0	452.4	512.8	487.4	...	...	...	533	544
20	584.2	501.6	558.8	533.4	...	585.8	503.2	560.4	531.8	...	...	...	584	595
22	641.4	...	...	...	...	...	...	...	...	...	...	...	...	...
24	692.2	603.2	666.8	641.4	...	693.7	604.8	668.3	639.8	...	...	...	692	703

66

ASME B16.5-2017

## GENERAL NOTES:

- (a) Dimensions are in millimeters. For dimensions in inch units, refer to Table II-4 of Mandatory Appendix II.  
(b) For facing requirements for flanges and flanged fittings, see paras. 6.3 and 6.4 and Figure 6.  
(c) For facing requirements for lapped joints, see para. 6.4.3 and Figure 6.  
(d) For facing tolerances, see para. 7.3.



(17)

**Table 4 Dimensions of Facings (Other Than Ring Joints, All Pressure Rating Classes) (Cont'd)**

---

NOTES:

- (1) For small male and female joints, care should be taken in the use of these dimensions to ensure that the inside diameter of the fitting or pipe is small enough to permit sufficient bearing surface to prevent the crushing of the gasket. This applies particularly on lines where the joint is made on the end of the pipe. The inside diameter of the fitting should match the inside diameter of the pipe as specified by the purchaser. Threaded companion flanges for small male and female joints are furnished with plain face and are threaded with American National Standard Locknut Thread (NPSL).
- (2) See para. 6.4.3 and Figure 6 for thickness and outside diameters of laps.
- (3) The height of the raised face is either 2 mm or 7 mm (see para. 6.4.1).
- (4) The height of the large and small male and tongue is 7 mm.
- (5) The depth of the groove or female is 5 mm.
- (6) The raised portion of the full face may be furnished unless otherwise specified on order.
- (7) Large male and female faces and large tongue and groove are not applicable to Class 150 because of potential dimensional conflicts.



# ANSI B16.5 CLASS 150 FLANGES

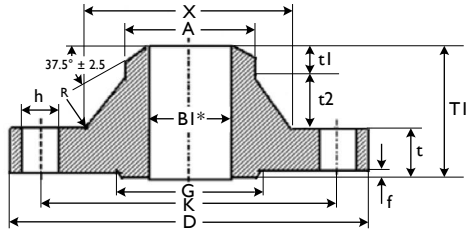

Welding Neck RF

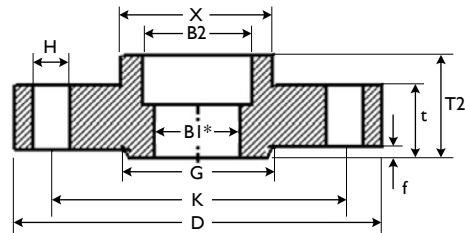

Socket Welding RF

## WELDING NECK RF STD\* DIMENSIONS (mm)

Size		Outside Diam.	Bore Diam.	Thick-ness	Total Thick-ness	Neck		Hub		Radius	Holes			Raised Face		Net Weight
mm	inch					D	BI*	t	T1		X	t2	t1	A	R	
15	½	88.90	15.75	11.18	47.75	30.23	29.21	7.37	21.34	3.05	15.75	4	60.45	35.05	1.60	0.49
20	¾	98.55	20.83	12.70	52.32	38.10	31.75	7.87	26.67	3.05	15.75	4	69.85	42.93	1.60	0.72
25	1	107.95	26.67	14.22	55.63	49.28	33.02	8.38	33.53	3.05	15.75	4	79.25	50.80	1.60	1.03
32	1¼	117.35	35.05	15.75	57.15	58.67	33.02	8.38	42.16	4.83	15.75	4	88.90	63.50	1.60	1.34
40	1½	127.00	40.89	17.53	61.98	65.02	35.56	8.89	48.26	6.35	15.75	4	98.55	73.15	1.60	1.74
50	2	152.40	52.58	19.05	63.50	77.72	35.56	8.89	60.45	7.87	19.05	4	120.65	91.95	1.60	2.60
65	2½	177.80	62.74	22.35	69.85	90.42	38.10	9.40	73.15	7.87	19.05	4	139.70	104.65	1.60	4.17
80	3	190.50	77.93	23.88	69.85	107.95	36.83	9.14	88.90	9.65	19.05	4	152.40	127.00	1.60	4.99
90	3½	215.90	90.17	23.88	71.37	122.17	38.10	9.40	101.60	9.65	19.05	8	177.80	139.70	1.60	6.18
100	4	228.60	102.26	23.88	76.20	134.87	41.91	10.41	114.30	11.18	19.05	8	190.50	157.23	1.60	6.98
125	5	254.00	128.19	23.88	88.90	163.58	52.07	12.95	141.22	11.18	22.35	8	215.90	185.67	1.60	8.72
150	6	279.40	154.05	25.40	88.90	192.02	50.80	12.70	168.40	12.70	22.35	8	241.30	215.90	1.60	10.74
200	8	342.90	202.72	28.45	101.60	246.13	58.42	14.73	219.20	12.70	22.35	8	298.45	269.75	1.60	17.68
250	10	406.40	254.51	30.23	101.60	304.80	57.15	14.22	273.05	12.70	25.40	12	361.95	323.85	1.60	24.25
300	12	482.60	304.80	31.75	114.30	365.25	66.04	16.51	323.85	12.70	25.40	12	431.80	381.00	1.60	36.93
350	14	533.40	336.55	35.05	127.00	400.05	73.66	18.29	355.60	12.70	28.45	12	476.25	412.75	1.60	48.88
400	16	596.90	387.35	36.58	127.00	457.20	72.39	18.03	406.40	12.70	28.45	16	539.75	469.90	1.60	60.47
450	18	635.00	438.15	39.62	139.70	504.95	80.01	20.07	457.20	12.70	31.75	16	577.85	533.40	1.60	68.37
500	20	698.50	488.95	42.93	144.53	558.80	81.28	20.32	508.00	12.70	31.75	20	635.00	584.20	1.60	84.60
600	24	812.80	590.55	47.75	152.40	663.45	83.82	20.83	609.60	12.70	35.05	20	749.30	692.15	1.60	115.33

\*See page 48 for bore diameter all schedules (S10 to XXS)

## SOCKET WELDING RF (STD\* and XS\*) DIMENSIONS (mm)

Size		Outside Diam.	Bore Diameter STD		Bore Diameter XS		Thick-ness	Socket Depth	Total Thick-ness	Diam. at Base of Hub	Holes			Raised Face		Net Weight
mm	inch		D	B2	BI*	B2					BI*	t	Y	T2	X	
15	½	88.90	22.35	15.75	22.35	13.97	11.18	9.65	15.75	30.23	15.75	4	60.45	35.05	1.60	0.41
20	¾	98.55	27.69	20.83	27.69	18.80	12.70	11.18	15.75	38.10	15.75	4	69.85	42.93	1.60	0.58
25	1	107.95	34.54	26.67	34.54	24.38	14.22	12.70	17.53	49.28	15.75	4	79.25	50.80	1.60	0.79
32	1¼	117.35	43.18	35.05	43.18	32.51	15.75	14.22	20.57	58.67	15.75	4	88.90	63.50	1.60	1.05
40	1½	127.00	49.53	40.89	49.53	38.10	17.53	15.75	22.35	65.02	15.75	4	98.55	73.15	1.60	1.36
50	2	152.40	61.98	52.58	61.98	49.28	19.05	17.53	25.40	77.72	19.05	4	120.65	91.95	1.60	2.12
65	2½	177.80	74.68	62.74	74.68	58.93	22.35	19.05	28.45	90.42	19.05	4	139.70	104.65	1.60	3.40
80	3	190.50	90.68	77.98	90.68	73.66	23.88	20.57	30.23	107.95	19.05	4	152.40	127.00	1.60	4.01
90	3½	215.90	103.38	90.17	103.38	85.34	23.88	22.35	31.75	122.17	19.05	8	177.80	139.70	1.60	4.99
100	4	228.60	116.08	102.36	116.08	97.28	23.88	23.88	33.27	134.87	19.05	8	190.50	157.23	1.60	5.50
125	5	254.00	143.76	128.27	143.76	122.17	23.88	23.88	36.58	163.58	22.35	8	215.90	185.67	1.60	6.43
150	6	279.40	170.69	154.18	170.69	146.30	25.40	26.92	39.62	192.02	22.35	8	241.30	215.90	1.60	7.88
200	8	342.90	221.49	253.49	221.49	193.80	28.45	31.75	44.45	246.13	22.35	8	298.45	269.75	1.60	10.88
250	10	406.40	276.35	254.51	276.35	247.65	30.23	33.27	49.28	304.80	25.40	12	361.95	323.85	1.60	17.70
300	12	482.60	327.15	304.80	327.15	298.45	31.75	39.62	55.63	365.25	25.40	12	431.80	381.00	1.60	27.65
350	14	533.40	359.16	336.55	359.16	330.20	35.05	41.40	57.15	400.05	28.45	12	476.25	412.75	1.60	36.29
400	16	596.90	410.46	387.35	410.46	381.00	36.58	44.45	63.50	457.20	28.45	16	539.75	469.90	1.60	47.18
450	18	635.00	461.77	438.15	461.77	431.80	39.62	49.28	68.33	504.95	31.75	16	577.85	533.40	1.60	51.39
500	20	698.50	513.08	488.95	513.08	482.60	42.93	54.10	73.15	558.80	31.75	20	635.00	584.20	1.60	64.91
600	24	812.80	615.95	590.55	615.95	584.20	47.75	63.50	82.55	663.45	35.05	20	749.30	692.15	1.60	90.73

\*See page 48 for bore diameter all schedules (S10 to XXS)

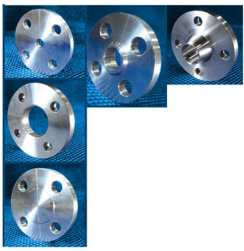

# ANSI B16.5 CLASS 150 FLANGES

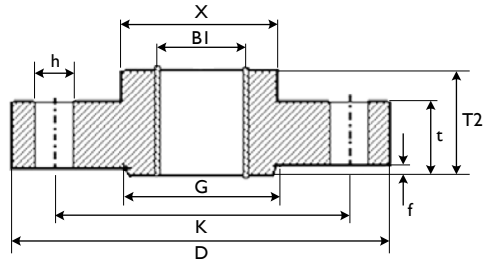

Threaded RD

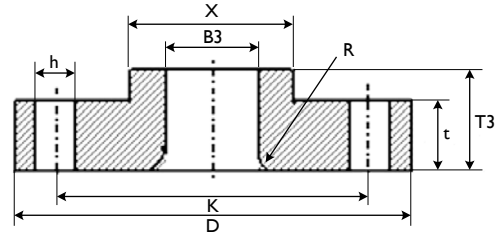

Lap Joint RF

## THREADED RF DIMENSIONS (mm)

Size		Outside Diam. D	Bore Diam. B2	Thick-ness t	Total Thick-ness T2	Diam. at Base of Hub X	Thread Length Q	Holes			Raised Face		Net Weight kg
mm	inch							Diam.	No.	P.C.D	Outside Diam. G	Thick-ness f	
mm	inch	D	B2	t	T2	X	Q	h	n	K	G	f	kg
15	½	88.90	22.35	11.18	15.75	30.23	15.75	15.75	4	60.45	35.05	1.60	0.40
20	¾	98.55	27.69	12.70	15.75	38.10	15.75	15.75	4	69.85	42.93	1.60	0.57
25	1	107.95	34.54	14.22	17.53	49.28	17.53	15.75	4	79.25	50.80	1.60	0.78
32	1¼	117.35	43.18	15.75	20.57	58.67	20.57	15.75	4	88.90	63.50	1.60	1.02
40	1½	127.00	49.53	17.53	22.35	65.02	22.35	15.75	4	98.55	73.15	1.60	1.33
50	2	152.40	61.98	19.05	25.40	77.72	25.40	19.05	4	120.65	91.95	1.60	2.07
65	2½	177.80	74.68	22.35	28.45	90.42	28.45	19.05	4	139.70	104.65	1.60	3.31
80	3	190.50	90.68	23.88	30.23	107.95	30.23	19.05	4	152.40	127.00	1.60	3.88
90	3½	215.90	103.38	23.88	31.75	122.17	31.75	19.05	8	177.80	139.70	1.60	4.84
100	4	228.60	116.08	23.88	33.27	134.87	33.27	19.05	8	190.50	157.23	1.60	5.32
125	5	254.00	143.76	23.88	36.58	163.58	36.58	22.35	8	215.90	185.67	1.60	6.10
150	6	279.40	170.69	25.40	39.62	192.02	39.62	22.35	8	241.30	215.90	1.60	7.46
200	8	342.90	221.49	28.45	44.45	246.13	44.45	22.35	8	298.45	269.75	1.60	12.07
250	10	406.40	276.35	30.23	49.28	304.80	49.28	25.40	12	361.95	323.85	1.60	16.56
300	12	482.60	327.15	31.75	55.63	365.25	55.63	25.40	12	431.80	381.00	1.60	26.26
350	14	533.40	359.16	35.05	57.15	400.05	57.15	28.45	12	476.25	412.75	1.60	34.76
400	16	596.90	410.46	36.58	63.50	457.20	63.50	28.45	16	539.75	469.90	1.60	45.02
450	18	635.00	461.77	39.62	68.33	504.95	68.33	31.75	16	577.85	533.40	1.60	48.90
500	20	698.50	513.08	42.93	73.15	558.80	73.15	31.75	20	635.00	584.20	1.60	62.07
600	24	812.80	615.95	47.75	82.55	663.45	82.55	35.05	20	749.30	692.15	1.60	87.13

## LAP JOINT RF DIMENSIONS (mm)

Size		Outside Diam. D	Bore Diam. B3	Thick-ness t	Length thru Hub T3	Diam. at Base of Hub X	Holes			Radius of Fillet R	Raised Face		Net Weight kg
mm	inch						Diam.	No.	P.C.D		Outside Diam. G	Thick-ness f	
mm	inch	D	B3	t	T3	X	h	n	K	R	G	f	kg
15	½	88.90	22.86	11.18	15.75	30.23	15.75	4	60.45	3.05	35.05	1.60	0.40
20	¾	98.55	28.19	12.70	15.75	38.10	15.75	4	69.85	3.05	42.93	1.60	0.57
25	1	107.95	35.05	14.22	17.53	49.28	15.75	4	79.25	3.05	50.80	1.60	0.78
32	1¼	117.35	43.69	15.75	20.57	58.67	15.75	4	88.90	4.83	63.50	1.60	1.02
40	1½	127.00	50.04	17.53	22.35	65.02	15.75	4	98.55	6.35	73.15	1.60	1.33
50	2	152.40	62.48	19.05	25.40	77.72	19.05	4	120.65	7.87	91.95	1.60	2.06
65	2½	177.80	75.44	22.35	28.45	90.42	19.05	4	139.70	7.87	104.65	1.60	3.29
80	3	190.50	91.44	23.88	30.23	107.95	19.05	4	152.40	9.65	127.00	1.60	3.85
90	3½	215.90	104.14	23.88	31.75	122.17	19.05	8	177.80	9.65	139.70	1.60	4.81
100	4	228.60	116.84	23.88	33.27	134.87	19.05	8	190.50	11.18	157.23	1.60	5.29
125	5	254.00	144.53	23.88	36.58	163.58	22.35	8	215.90	11.18	185.67	1.60	6.05
150	6	279.40	171.45	25.40	39.62	192.02	22.35	8	241.30	12.70	215.90	1.60	7.39
200	8	342.90	222.25	28.45	44.45	246.13	22.35	8	298.45	12.70	269.75	1.60	11.98
250	10	406.40	277.37	30.23	49.28	304.80	25.40	12	361.95	12.70	323.85	1.60	16.38
300	12	482.60	328.17	31.75	55.63	365.25	25.40	12	431.80	12.70	381.00	1.60	26.03
350	14	533.40	360.17	35.05	57.15	400.05	28.45	12	476.25	12.70	412.75	1.60	38.63
400	16	596.90	411.23	36.58	63.50	457.20	28.45	16	539.75	12.70	469.90	1.60	50.65
450	18	635.00	462.28	39.62	68.33	504.95	31.75	16	577.85	12.70	533.40	1.60	55.94
500	20	698.50	514.35	42.93	73.15	558.80	31.75	20	635.00	12.70	584.20	1.60	70.30
600	24	812.80	615.95	47.75	82.55	663.45	35.05	20	749.30	12.70	692.15	1.60	97.89

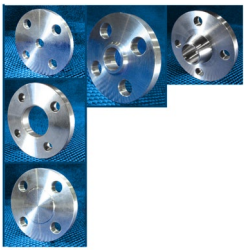

# ANSI B16.5 CLASS 150 FLANGES

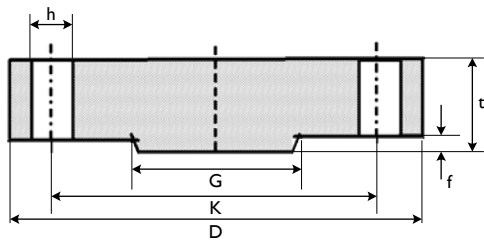

Blind RF

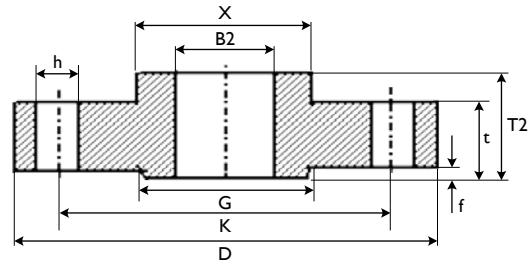

Slip On

## BLIND RF DIMENSIONS (mm)

Size		Outside Diameter	Thickness	Holes			Raised Face		Net Weight
				Diameter	Number	P.C.D	Outside Diameter	Thickness	
mm	inch	D	t	h	n	K	G	f	kg
15	½	88.90	11.18	15.75	4	60.45	35.05	1.60	0.42
20	¾	98.55	12.70	15.75	4	69.85	42.93	1.60	0.62
25	1	107.95	14.22	15.75	4	79.25	50.80	1.60	0.86
32	1¼	117.35	15.75	15.75	4	88.90	63.50	1.60	1.16
40	1½	127.00	17.53	15.75	4	98.55	73.15	1.60	1.54
50	2	152.40	19.05	19.05	4	120.65	91.95	1.60	2.43
65	2½	177.80	22.35	19.05	4	139.70	104.65	1.60	3.98
80	3	190.50	23.88	19.05	4	152.40	127.00	1.60	4.95
90	3½	215.90	23.88	19.05	8	177.80	139.70	1.60	6.21
100	4	228.60	23.88	19.05	8	190.50	157.23	1.60	7.04
125	5	254.00	23.88	22.35	8	215.90	185.67	1.60	8.67
150	6	279.40	25.40	22.35	8	241.30	215.90	1.60	11.34
200	8	342.90	28.45	22.35	8	298.45	269.75	1.60	19.54
250	10	406.40	30.23	25.40	12	361.95	323.85	1.60	28.85
300	12	482.60	31.75	25.40	12	431.80	381.00	1.60	43.33
350	14	533.40	35.05	28.45	12	476.25	412.75	1.60	58.41
400	16	596.90	36.58	28.45	16	539.75	469.90	1.60	76.28
450	18	635.00	39.62	31.75	16	577.85	533.40	1.60	93.60
500	20	698.50	42.93	31.75	20	635.00	584.20	1.60	122.62
600	24	812.80	47.75	35.05	20	749.30	692.15	1.60	185.79

## SLIP ON RF DIMENSIONS (mm)

Size		Outside Diam.	Bore Diam.	Thickness	Total Thickness	Diam. of Base of Hub	Holes			Raised Face		Net Weight
							Diam.	No.	P.C.D	Outside Diam.	Thickness	
mm	inch	D	B2	t	T2	X	h	n	K	G	f	kg
15	½	88.90	22.35	11.18	15.75	30.23	15.75	4	60.45	35.05	1.60	0.40
20	¾	98.55	27.69	12.70	15.75	38.10	15.75	4	69.85	42.93	1.60	0.57
25	1	107.95	34.54	14.22	17.53	49.28	15.75	4	79.25	50.80	1.60	0.78
32	1¼	117.35	43.18	15.75	20.57	58.67	15.75	4	88.90	63.50	1.60	1.02
40	1½	127.00	49.53	17.53	22.35	65.02	15.75	4	98.55	73.15	1.60	1.33
50	2	152.40	61.98	19.05	25.40	77.72	19.05	4	120.65	91.95	1.60	2.07
65	2½	177.80	74.68	22.35	28.45	90.42	19.05	4	139.70	104.65	1.60	3.31
80	3	190.50	90.68	23.88	30.23	107.95	19.05	4	152.40	127.00	1.60	3.88
90	3½	215.90	103.38	23.88	31.75	122.17	19.05	8	177.80	139.70	1.60	4.84
100	4	228.60	116.06	23.88	33.27	134.87	19.05	8	190.50	157.23	1.60	5.32
125	5	254.00	143.76	23.88	36.58	163.58	22.35	8	215.90	185.67	1.60	6.10
150	6	279.40	170.69	25.40	39.62	192.02	22.35	8	241.30	215.90	1.60	7.46
200	8	342.90	221.49	28.45	44.45	246.13	22.35	8	298.45	269.75	1.60	12.07
250	10	406.40	276.35	30.23	49.28	304.80	25.40	12	361.95	323.85	1.60	16.56
300	12	482.60	327.15	31.75	55.63	365.25	25.40	12	431.80	381.00	1.60	26.26
350	14	533.40	359.16	35.05	57.15	400.05	28.45	12	476.25	412.75	1.60	34.76
400	16	596.90	410.46	36.58	63.50	457.20	28.45	16	539.75	469.90	1.60	45.02
450	18	635.00	461.77	39.62	68.33	504.95	31.75	16	577.85	533.40	1.60	48.90
500	20	698.50	513.08	42.93	73.15	558.80	31.75	20	635.00	584.20	1.60	62.07
600	24	812.80	615.95	47.75	82.55	663.45	35.05	20	749.30	692.15	1.60	87.13

**Table 6 Reducing Threaded and Slip-On Pipe Flanges for Classes 150 Through 2500 Pipe Flanges**

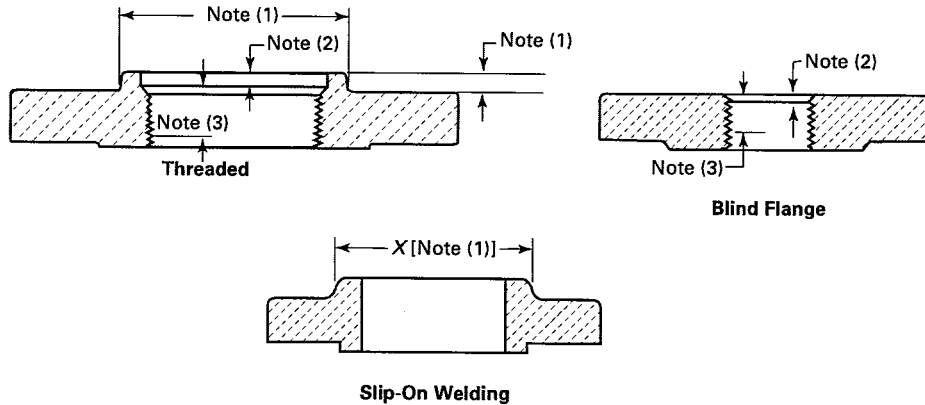

1	2	3	4	5	6
Nominal Pipe Size [Note (4)]	Smallest Size of Reducing Outlet Requiring Hub Flanges [Note (1)]	Nominal Pipe Size [Note (4)]	Smallest Size of Reducing Outlet Requiring Hub Flanges [Note (1)]	Nominal Pipe Size [Note (4)]	Smallest Size of Reducing Outlet Requiring Hub Flanges [Note (1)]
NPS	NPS	NPS	NPS	NPS	NPS
1	1/2	3 1/2	1 1/2	12	3 1/2
1 1/4	1/2	4	1 1/2	14	3 1/2
1 1/2	1/2	5	1 1/2	16	4
2	1	6	2 1/2	18	4
2 1/2	1 1/4	8	3	20	4
3	1 1/4	10	3 1/2	24	4

GENERAL NOTE: Dimensions are in millimeters. For dimensions in inches, refer to Mandatory Appendix II, Table II-6.

NOTES:

- (1) The hub dimensions shall be at least as large as those of the standard flanges of the size to which the reduction is being machined, except flanges reducing to a size smaller than those of Columns 2, 4, and 6 may be made from blind flanges (see Example).
- (2) Class 150 flanges do not have a counterbore. Class 300 and higher pressure flanges will have depth of counterbore  $Q$  of 7 mm for NPS 2 and smaller tapping and 9.5 mm for NPS 2 1/2 and larger. The diameter  $Q$  of counterbore is the same as that given in the tables of threaded flanges for the corresponding tapping.
- (3) Minimum length of effective threads shall be at least equal dimension  $T$  of the corresponding pressure class threaded flange as shown in tables but does not necessarily extend for the face of the flange. For thread of threaded flanges, see para. 6.9.
- (4) For method of designating reducing threaded and reducing slip-on flanges, see para. 3.3 and Examples below.

EXAMPLES:

- (1) The size designation is NPS 6 x 2 1/2 — Class 300 reducing threaded flange. This flange has the following dimensions:  
 NPS 2 1/2 = taper pipe thread tapping (ASME B1.20.1)  
 320 mm = diameter of regular NPS 6 Class 300 threaded flange  
 35 mm = thickness of regular NPS 6 Class 300 threaded flange  
 178 mm = diameter of hub for regular NPS 5 Class 300 threaded flange. Hub diameter may be one size small to reduce machining. In this example, a hub diameter of NPS 2 1/2 would be the smallest acceptable.  
 15.5 mm = height of hub for regular NPS 5 Class 300 threaded flange
- (2) The size designation is NPS 6 x 2 — Class 300 reducing threaded flange. Use regular NPS 6 Class 300 blind flange tapped with NPS 2 taper pipe thread (ASME B1.20.1).

(17)

**Table 7 Templates for Drilling Class 150 Pipe Flanges and Flanged Fittings**

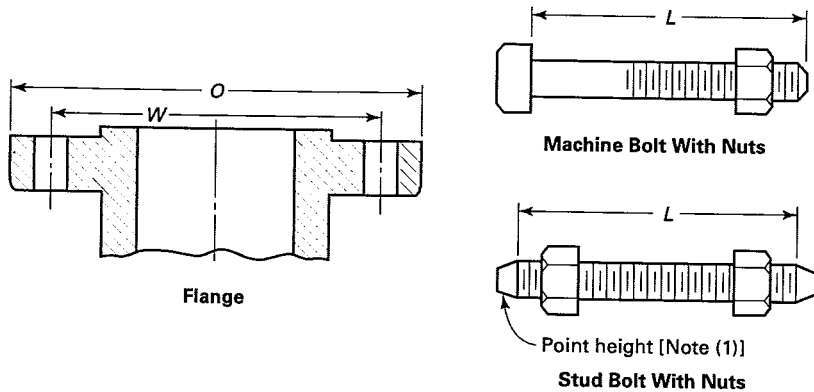

Nominal Pipe Size	Outside Diameter of Flange, <i>O</i>	Drilling [Notes (2), (3)]				Length of Bolts, <i>L</i> [Note (4)]		
		Diameter of Bolt Circle, <i>W</i>	Diameter of Bolt Holes, in.	Number of Bolts	Diameter of Bolts, in.	Stud Bolts [Note (1)]		Machine Bolts
						2-mm Raised Face	Ring Joint	2-mm Raised Face
1/2	90	60.3	5/8	4	1/2	55	...	50
3/4	100	69.9	5/8	4	1/2	65	...	50
1	110	79.4	5/8	4	1/2	65	75	55
1 1/4	115	88.9	5/8	4	1/2	70	85	55
1 1/2	125	98.4	5/8	4	1/2	70	85	65
2	150	120.7	3/4	4	5/8	85	95	70
2 1/2	180	139.7	3/4	4	5/8	90	100	75
3	190	152.4	3/4	4	5/8	90	100	75
3 1/2	215	177.8	3/4	8	5/8	90	100	75
4	230	190.5	3/4	8	5/8	90	100	75
5	255	215.9	7/8	8	3/4	95	110	85
6	280	241.3	7/8	8	3/4	100	115	85
8	345	298.5	7/8	8	3/4	110	120	90
10	405	362.0	1	12	7/8	115	125	100
12	485	431.8	1	12	7/8	120	135	100
14	535	476.3	1 1/8	12	1	135	145	115
16	595	539.8	1 1/8	16	1	135	145	115
18	635	577.9	1 1/4	16	1 1/8	145	160	125
20	700	635.0	1 1/4	20	1 1/8	160	170	140
22	750	692.2	1 3/8	20	1 1/4	170	185	150
24	815	749.3	1 3/8	20	1 1/4	170	185	150

**GENERAL NOTES:**

- (a) Dimensions of Table 7 are in millimeters, except for diameters of bolts and bolt holes, which are in inch units. For dimensions in inch units, refer to Mandatory Appendix II, Table II-7.
- (b) For other dimensions, see Tables 8 and 9.

**NOTES:**

- (1) The length of the stud bolt does not include the height of the points (see para. 6.10.2).
- (2) For flange bolt holes, see para. 6.5.
- (3) For spot facing, see para. 6.6.
- (4) Bolt lengths not shown in the table may be determined in accordance with Nonmandatory Appendix C (see para. 6.10.2).

(17)

Table 8 Dimensions of Class 150 Flanges

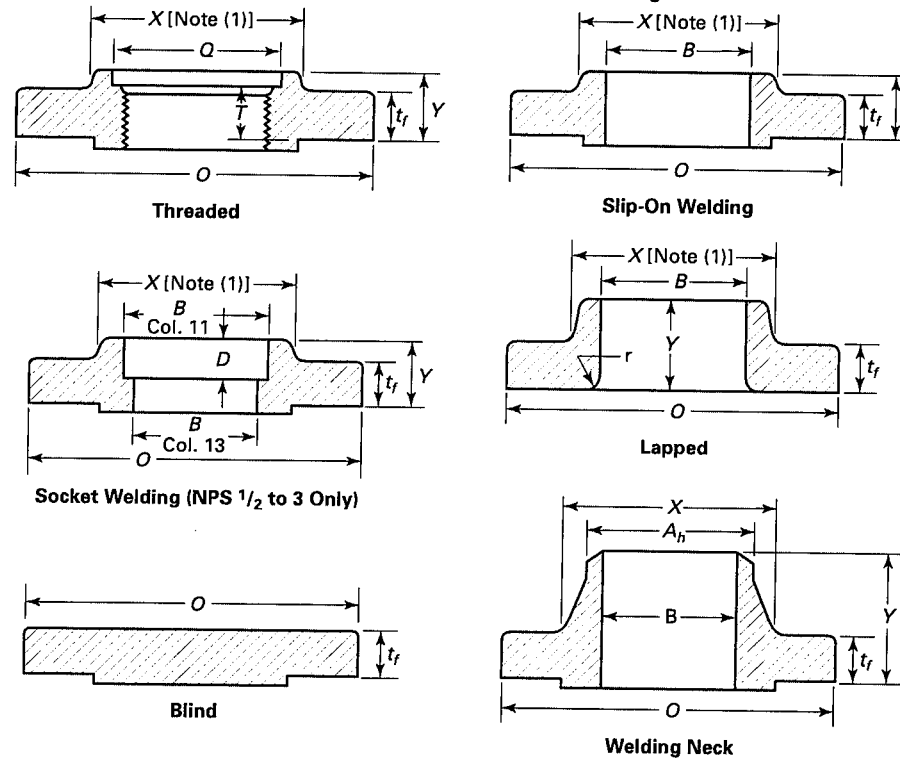

1	2	3	4	5	6	7			8	9	10	11		12	13	14	15
Nominal Pipe Size, NPS	Outside Diameter of Flange, $O$	Minimum Thickness of Flange, $t_f$ [Notes (2)-(4)]	Minimum Thickness Lap Joint, $t_f$	Diameter of Hub, $X$	Hub Diameter Beginning of Chamfer Welding Neck, $A_h$ [Note (5)]	Length Through Hub			Welding Neck, $Y$	Minimum Thread Length Threaded, $T$ [Note (6)]	Bore		Welding Neck/Socket Welding, $B$ [Note (7)]	Corner Bore Radius of Lapped Flange and Pipe, $r$	Depth of Socket, $D$		
						Threaded/Slip-on/Socket Welding, $Y$	Lapped, $Y$	Welding Neck, $Y$			Minimum Slip-on/Socket Welding, $B$	Minimum Lapped, $B$					
1/2	90	9.6	11.2	30	21.3	14	16	46	16	22.2	22.9	15.8	3	10			
3/4	100	11.2	12.7	38	26.7	14	16	51	16	27.7	28.2	20.9	3	11			
1	110	12.7	14.3	49	33.4	16	17	54	17	34.5	34.9	26.6	3	13			
1 1/4	115	14.3	15.9	59	42.2	19	21	56	21	43.2	43.7	35.1	5	14			
1 1/2	125	15.9	17.5	65	48.3	21	22	60	22	49.5	50.0	40.9	6	16			

77



(17)

Table 8 Dimensions of Class 150 Flanges (Cont'd)

1	2	3	4	5	6	7			8	9	10	11		12	13	14	15
Nominal Pipe Size, NPS	Outside Diameter of Flange, $O$	Minimum Thickness of Flange, $t_f$ [Notes (2)-(4)]	Minimum Thickness Lap Joint, $t_l$	Diameter of Hub, $X$	Hub Diameter Beginning of Chamfer Welding Neck, $A_h$ [Note (5)]	Length Through Hub			Welding Neck, $Y$	Minimum Thread Length Threaded, $T$ [Note (6)]	Bore		Welding Neck/ Socket Welding, $B$ [Note (7)]	Corner Bore Radius of Lapped Flange and Pipe, $r$	Depth of Socket, $D$		
						Threaded/ Slip-on/ Socket Welding, $Y$	Lapped, $Y$	Minimum Slip-on/ Socket Welding, $B$			Minimum Lapped, $B$						
2	150	17.5	19.1	78	60.3	24	25	62	25	61.9	62.5	52.5	8	17			
2½	180	20.7	22.3	90	73.0	27	29	68	29	74.6	75.4	62.7	8	19			
3	190	22.3	23.9	108	88.9	29	30	68	30	90.7	91.4	77.9	10	21			
3½	215	22.3	23.9	122	101.6	30	32	70	32	103.4	104.1	90.1	10	...			
4	230	22.3	23.9	135	114.3	32	33	75	33	116.1	116.8	102.3	11	...			
5	255	22.3	23.9	164	141.3	35	36	87	36	143.8	144.4	128.2	11	...			
6	280	23.9	25.4	192	168.3	38	40	87	40	170.7	171.4	154.1	13	...			
8	345	27.0	28.6	246	219.1	43	44	100	44	221.5	222.2	202.7	13	...			
10	405	28.6	30.2	305	273.0	48	49	100	49	276.2	277.4	254.6	13	...			
12	485	30.2	31.8	365	323.8	54	56	113	56	327.0	328.2	304.8	13	...			
14	535	33.4	35.0	400	355.6	56	79	125	57	359.2	360.2	Note (8)	13	...			
16	595	35.0	36.6	457	406.4	62	87	125	64	410.5	411.2	Note (8)	13	...			
18	635	38.1	39.7	505	457.0	67	97	138	68	461.8	462.3	Note (8)	13	...			
20	700	41.3	42.9	559	508.0	71	103	143	73	513.1	514.4	Note (8)	13	...			
22	750	44.5	46.1	610	558.8	78	108	148	...	564.4	565.2	Note (8)	13	...			
24	815	46.1	47.7	663	610.0	81	111	151	83	616.0	616.0	Note (8)	13	...			

## GENERAL NOTES:

- (a) Dimensions of Table 8 are in millimeters. For dimensions in inches, refer to Table II-8 of Mandatory Appendix II.  
 (b) For tolerance, see section 7.  
 (c) For facings, see para. 6.4.  
 (d) For flange bolt holes, see para. 6.5 and Table 7.  
 (e) For spot facing, see para. 6.6.  
 (f) For reducing threaded and slip-on flanges, see Table 6.  
 (g) Blind flanges may be made with or without hubs at the manufacturer's option.  
 (h) For reducing welding neck flanges, see para. 6.8.

## NOTES:

- (1) This dimension is for large end of hub, which may be straight or tapered. Taper shall not exceed 7 deg on threaded, slip-on, socket-welding, and lapped flanges. This dimension is defined as the diameter at the intersection between the hub taper and back face of the flange.

(17)

**Table 8 Dimensions of Class 150 Flanges (Cont'd)**

NOTES (Cont'd):

- (2) The minimum thickness of these loose flanges, in sizes NPS 3 1/2 and smaller, is slightly greater than the thickness of flanges on fittings, Table 9, which are reinforced by being cast integral with the body of the fitting.
- (3) These flanges may be supplied with a flat face. The flat face may be either the full  $t_f$  dimension of thickness plus 2 mm or the  $t_f$  dimension thickness without the raised face height. See para 6.3.2 for additional restrictions.
- (4) The flange dimensions illustrated are for regularly furnished 2-mm raised face (except lapped); for requirements of other facings, see Figure 6.
- (5) For welding end bevel (see para. 6.7).
- (6) For thread of threaded flanges, see para. 6.9.
- (7) Dimensions in Column 13 correspond to the inside diameters of pipe as given in ASME B36.10M for standard wall pipe. Thickness of standard wall is the same as Schedule 40 in sizes NPS 10 and smaller. Tolerances in para. 7.5.2 apply. These bore sizes are furnished unless otherwise specified by the purchaser.
- (8) To be specified by the purchaser.

Table 9 Dimensions of Class 150 Flanged Fittings

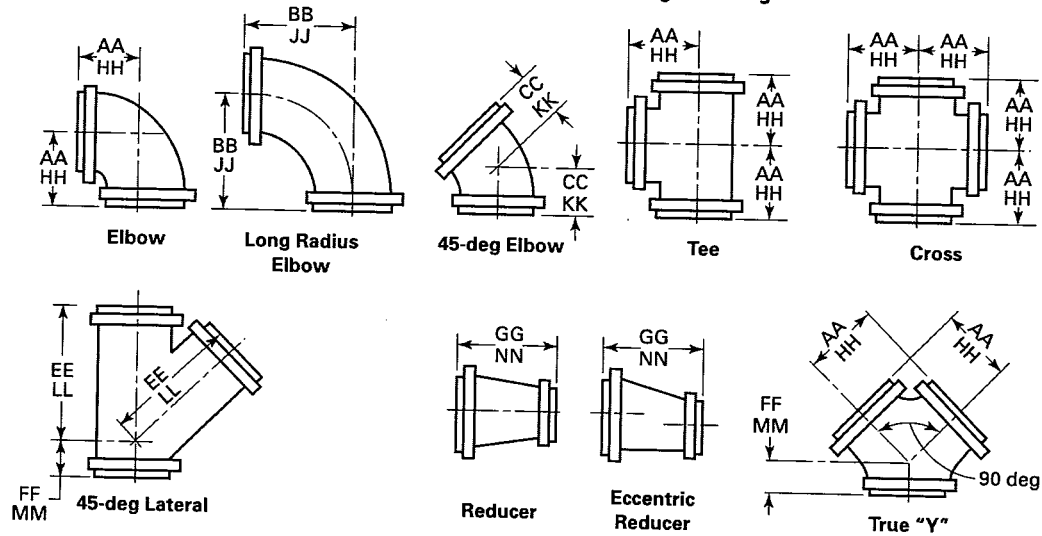

1	2	3	4	5	2-mm Raised Face [Note (4)]						11	12
					6	7	8	9	10	Ring Joint [Note(4)]		
Nominal Pipe Size, NPS	Outside Diameter of Flange, O	Minimum Thickness of Flange, $t_f$ [Notes (1)-(3)]	Minimum Wall Thickness of Fitting, $t_m$	Inside Diameter of Fitting, d	Center-to-Contact Surface of Raised Face Elbow, Tee, Cross, and True "Y," AA	Center-to-Contact Surface of Raised Face Long Radius Elbow, BB	Center-to-Contact Surface of Raised Face 45-deg Elbow, CC	Long Center-to-Contact Surface of Raised Face Lateral, EE	Short Center-to-Contact Surface of Raised Face Lateral and True "Y," FF	Contact Surface-to-Contact Surface of Raised Face Reducer, GG [Note (5)]	Center-to-End Elbow, Tee, Cross, and True "Y," HH [Note (6)]	
1/2	90	8.0	2.8	13	...	...	...	...	...	...	...	
3/4	100	8.9	3.2	19	...	...	...	...	...	...	...	
1	110	9.6	4.0	25	89	127	44	146	44	114	95	
1 1/4	115	11.2	4.8	32	95	140	51	159	44	114	102	
1 1/2	125	12.7	4.8	38	102	152	57	178	51	114	108	
2	150	14.3	5.6	51	114	165	64	203	64	127	121	
2 1/2	180	15.9	5.6	64	127	178	76	241	64	140	133	
3	190	17.5	5.6	76	140	197	76	254	76	152	146	
3 1/2	215	19.1	6.4	89	152	216	89	292	76	165	159	
4	230	22.3	6.4	102	165	229	102	305	76	178	171	
5	255	22.3	7.1	127	190	260	114	343	89	203	197	
6	280	23.9	7.1	152	203	292	127	368	89	229	210	
8	345	27.0	7.9	203	229	356	140	444	114	279	235	
10	405	28.6	8.7	254	279	419	165	521	127	305	286	
12	485	30.2	9.5	305	305	483	190	622	140	356	311	
14	535	33.4	10.3	337	356	546	190	686	152	406	362	
16	595	35.0	11.1	387	381	610	203	762	165	457	387	

Table 9 Dimensions of Class 150 Flanged Fittings (Cont'd)

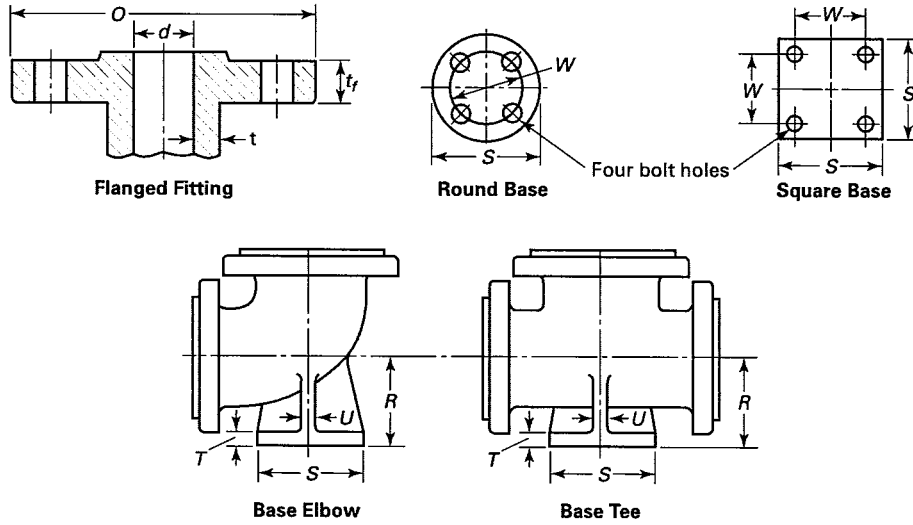

13	14	15	16	17	18	19	20	21	22	23	1	
Ring Joint [Note (4)]										Base Drilling [Note (11)]		
Center-to-End Long Radius Elbow, JJ [Note (6)]	Center-to-End 45-deg Elbow, KK [Note (6)]	Long Center-to-End Lateral, LL [Note (6)]	Short Center-to-End Lateral and True "Y," MM [Note (6)]	End-to-End Reducer, NN [Notes (5), (6)]	Center-to-Base, R [Notes (7)-(9)]	Diameter of Round Base or Width of Square Base, S [Note (7)]	Thickness of Base, T [Notes (7)-(10)]	Thickness of Ribs, U [Note (7)]	Bolt Circle or Bolt Spacing, W	Diameter of Drilled Holes	Nominal Pipe Size, NPS	
...	...	...	...	...	...	...	...	...	...	...	1/2	
...	...	...	...	...	...	...	...	...	...	...	3/4	
133	51	152	51	...	...	...	...	...	...	...	1	
146	57	165	51	...	...	...	...	...	...	...	1 1/4	
159	64	184	57	...	...	...	...	...	...	...	1 1/2	
171	70	210	70	...	105	117	13	13	88.9	5/8	2	
184	83	248	70	...	114	117	13	13	88.9	5/8	2 1/2	
203	83	260	70	...	124	127	14	14	98.4	5/8	3	
222	95	298	83	...	133	127	14	14	98.4	5/8	3 1/2	
235	108	311	83	...	140	152	16	16	120.6	3/4	4	
267	121	349	95	...	159	178	17	17	139.7	3/4	5	
298	133	375	95	...	178	178	17	17	139.7	3/4	6	
362	146	451	121	...	213	229	24	24	190.5	3/4	8	
425	171	527	133	...	248	229	24	24	190.5	3/4	10	
489	197	629	146	...	286	279	25	25	241.3	7/8	12	
552	197	692	159	...	318	279	25	25	241.3	7/8	14	
616	210	768	171	...	349	279	25	25	241.3	7/8	16	

Table 9 Dimensions of Class 150 Flanged Fittings (Cont'd)

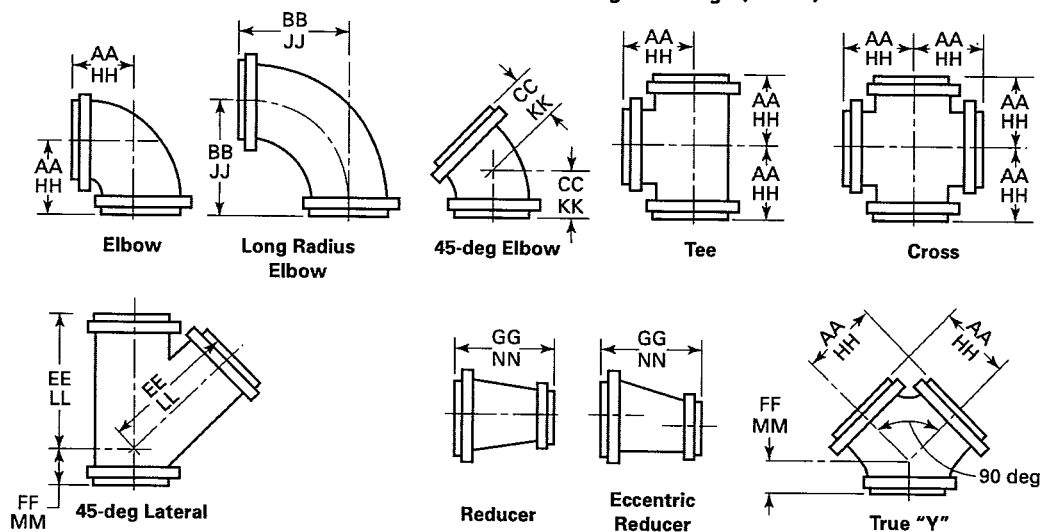

1	2	3	4	5	6	7	8	9	10	11	12	
					2-mm Raised Face [Note (4)]							Ring Joint [Note(4)]
					Center-to-Surface of Raised Face Elbow, Tee, Cross, and True "Y," AA	Center-to-Surface of Raised Face Long Radius Elbow, BB	Center-to-Surface of Raised Face 45-deg Elbow, CC	Long Center-to-Surface of Raised Face Lateral, EE	Short Center-to-Surface of Raised Face Lateral and True "Y," FF	Contact Surface of Raised Face Reducer, GG	Contact Surface of Raised Face Tee, Cross, and True "Y," HH	Center-to-End Elbow, Tee, Cross, and True "Y," HH [Note (6)]
Nominal Pipe Size, NPS	Outside Diameter of Flange, <i>O</i>	Minimum Thickness of Flange, <i>t<sub>f</sub></i> [Notes (1)-(3)]	Minimum Wall Thickness of Fitting, <i>t<sub>m</sub></i>	Inside Diameter of Fitting, <i>d</i>								
18	635	38.1	11.9	438	419	673	216	813	178	483	425	
20	700	41.3	12.7	489	457	737	241	889	203	508	464	
24	815	46.1	14.5	591	559	864	279	1029	229	610	565	

Table 9 Dimensions of Class 150 Flanged Fittings (Cont'd)

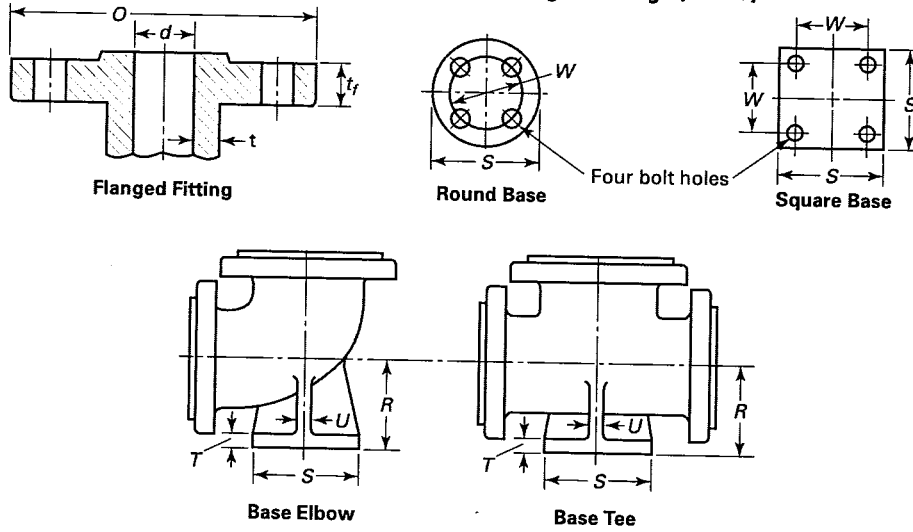

13	14	15	16	17	18	19	20	21	22	23	1
Ring Joint [Note (4)]									Base Drilling [Note (11)]		
Center-to-End Long Radius Elbow, JJ [Note (6)]	Center-to-End 45-deg Elbow, KK [Note (6)]	Long Center-to-End Lateral, LL [Note (6)]	Short Center-to-End Lateral and True "Y," MM [Note (6)]	End-to-End Reducer, NN [Notes (5), (6)]	Center-to-Base, R [Notes (7)-(9)]	Diameter of Round Base or Width of Square Base, S [Note (7)]	Thickness of Base, T [Notes (7)-(10)]	Thickness of Ribs, U [Note (7)]	Bolt Circle or Bolt Spacing, W	Diameter of Drilled Holes	Nominal Pipe Size, NPS
679	222	819	184	...	381	343	29	29	298.4	7/8	18
743	248	895	210	...	406	343	29	29	298.4	7/8	20
870	286	1035	235	...	470	343	29	29	298.4	7/8	24